

NET June 2018 (Code B)

PART A

- Q1. When a farmer was asked as to how many animals he had, he replied that all but two were cows, all but two were horses and all but two were pigs. How many animals did he have?
- (a) 3 (b) 6 (c) 8 (d) 12
- Q2. Nine eleventh of the members of a parliamentary committee are men. Of the men, two-thirds are from the Rajya Sabha. Further, $7/11$ of the total committee members are from the Rajya Sabha. What fraction of the total number are women from the Lok Sabha?
- (a) $1/11$ (b) $6/11$ (c) $2/11$ (d) $3/11$
- Q3. A librarian is arranging a thirteen-volume encyclopedia on the shelf from left to right in the following order of volume numbers: 8,11,5,4,9,1,7,6,10,3,12,2. In this pattern, where should the volume 13 be placed?
- (a) Leftmost (b) Rightmost
(c) Between 10 and 3 (d) Between 9 and 1
- Q4. Pick the correct statement:
- (a) The sky is blue because Sir C.V. Raman gave the correct explanation.
(b) Copernicus believed that the Sun, and not the Earth, was at the centre of the Solar system.
(c) The sky appears blue when seen from the Moon..
(d) No solar eclipse is visible for an astronaut standing on the Moon.
- Q5. What is the last digit of $(2017)^{2017}$?
- (a) 1 (b) 3 (c) 7 (d) 9
- Q6. What is the value of $(1 + 3 + 5 + 7 + \dots + 4033) + 7983 \times 2017$?
- (a) 20170000 (b) 20172017 (c) 20171720 (d) 20172020

- Q7. Path of a ray of light between two mirrors is shown in the diagram. If the length of each mirror is ' l ', what is the total path length of the ray between the mirrors?

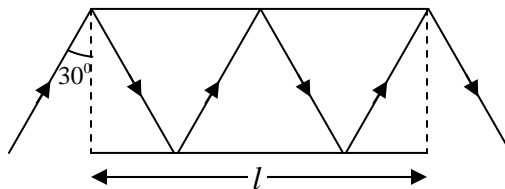

- (a) $\frac{3}{4}l$ (b) $\frac{4}{3}l$ (c) $\frac{3}{2}l$ (d) $2l$
- Q8. In a group of 11 persons, each shakes hand with every other once and only once. What is the total number of such handshakes?
 (a) 110 (b) 121 (c) 55 (d) 66
- Q9. Suppose (i) " $A * B$ " means " A is the father of B ", (ii) " $A \Delta B$ " means " A is the husband of B ", (iii) " $A \nabla B$ " means " A is the wife of B ", (iv) " $A \square B$ " means " A is the sister of B ". Which of the following represents " C is the father-in-law of the sister of D "
 (a) $C \nabla E * F \square D$ (b) $C * E \nabla F \square D$ (c) $C \Delta E * F \square D$ (d) $C * E \Delta F \square D$
- Q10. In a 100 m race A beats B by 10 m. B beats C by 5 m. By how many meters does A beat C ?
 (a) 15.0 m (b) 5.5 m (c) 10.5 m (d) 14.5 m
- Q11. If all the angles of a triangle are prime numbers, which of the following could be one such angle?
 (a) 89° (b) 79° (c) 59° (d) 29°
- Q12. A water tank that is 40% empty holds 40 L more water than when it is 40% full. How much water does it hold when it is full?
 (a) 100 L (b) 75 L (c) 120 L (d) 200 L
- Q13. How much gold and copper (in g), respectively, are required to make a 120 g bar of 22 carat gold?
 (a) 90 and 30 (b) 100 and 20
 (c) 110 and 10 (d) 120 and 0

Q14. Which of the following be the correct pattern in the empty square?

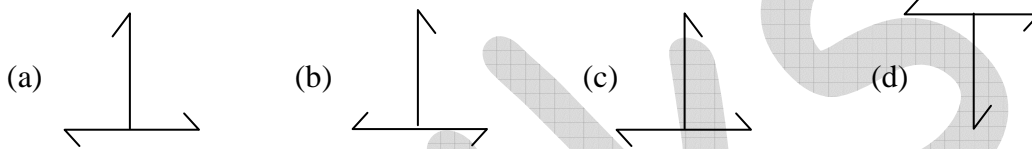
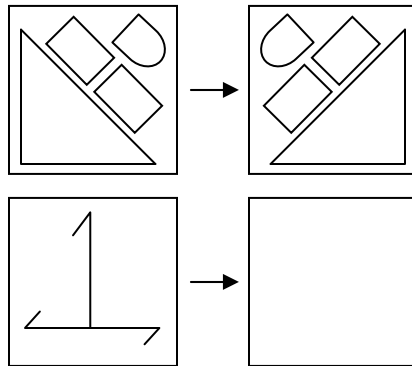

Q15. Areas of the three rectangles inside the full rectangle are given in the diagram

	8
12	4

What is the area of the full rectangle?

- (a) 36 (b) 48 (c) 72 (d) 96

Q16. The university needs to appoint a new Vice Chancellor which will be based on seniority. Ms. West is less senior to Mr. North but more senior to Ms. East. Mr. South is senior to Ms. West but junior to Mr. North. If the senior most declines the assignment, then who will be the new vice Chancellor of the University?

- (a) Mr. North (b) Mr. East (c) Ms. West (d) Mr. South

Q17. The prices of diamonds having a particular colour and clarity are tabulated below:

Weight of diamond (in carats)	Price of diamond (in rupees / carat)
0.25	1 lakh
0.5	2 lakh
1	4 lakh
2	8 lakh

How many 0.25 carat diamonds can be purchased for the price of a 2 carat diamond?

- (a) 8 (b) 16 (c) 32 (d) 64

- Q18. In a sequence of 24 positive integers, the product of any two consecutive integer is 24 .
If the 17th member of the sequence is 6 , the 7th member is
(a) 24 (b) 4 (c) 6 (d) 17
- Q19. Mohan lent Geeta as much money as she already had, she then spent Rs. 10 . Next day, he again lent as much money as Geeta now had, and she spent Rs. 10 again. On the third day, Mohan again lent as much money as Geeta now had, and she again spent Rs. 10 .If Geeta was left with no money at the end of third day, how much money did she have initially?
(a) Rs.11.25 (b) Rs.10 (c) Rs. 7.75 (d) Rs.8.75
- Q20. The distribution of marks of students in a class is given by the following chart:

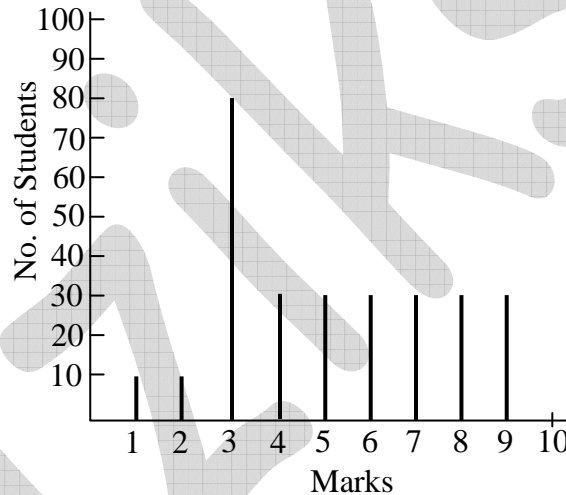

If 3.30 marks is the passing score in a 10 mark question paper, which of the following is false?

- (a) Majority of the students have scored above the pass mark
(b) mode of the distribution is 3
(c) Average marks of passing students is above 55%
(d) Average marks of students who have failed is below 20%

PART B

Q21. Consider the following ordinary differential equation

$$\frac{d^2x}{dt^2} + \frac{1}{x} \left(\frac{dx}{dt} \right)^2 - \frac{dx}{dt} = 0$$

with the boundary conditions $x(t=0)=0$ and $x(t=1)=1$. The value of $x(t)$ at $t=2$ is

- (a) $\sqrt{e-1}$ (b) $\sqrt{e^2+1}$ (c) $\sqrt{e+1}$ (d) $\sqrt{e^2-1}$

Q22. What is the value of a for which $f(x, y) = 2x + 3(x^2 - y^2) + 2i(3xy + ay)$ is an analytic function of complex variable $z = x + iy$

- (a) 1 (b) 0 (c) 3 (d) 2

Q23. Two particles A and B move with relativistic velocities of equal magnitude v , but in opposite directions, along the x -axis of an inertial frame of reference. The magnitude of the velocity of A , as seen from the rest frame of B , is

- (a) $\frac{2v}{\left(1 - \frac{v^2}{c^2}\right)}$ (b) $\frac{2v}{\left(1 + \frac{v^2}{c^2}\right)}$ (c) $2v \sqrt{\frac{c-v}{c+v}}$ (d) $\frac{2v}{\sqrt{1 - \frac{v^2}{c^2}}}$

Q24. Which of the following figures best describes the trajectory of a particle moving in a repulsive central potential $V(r) = \frac{a}{r}$ ($a > 0$ is a constant)?

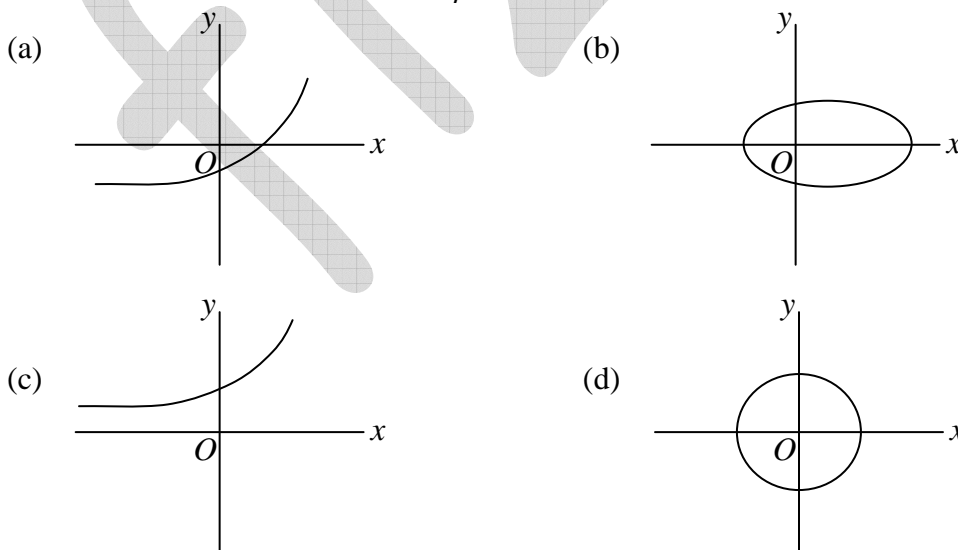

Q25. Consider the three vectors $\vec{v}_1 = 2\hat{i} + 3\hat{k}$, $\vec{v}_2 = \hat{i} + 2\hat{j} + 2\hat{k}$ and $\vec{v}_3 = 5\hat{i} + \hat{j} + a\hat{k}$ where \hat{i} , \hat{j} and \hat{k} are the standard unit vectors in a three-dimensional Euclidean space. These vectors will be linearly dependent if the value of a is

- (a) $\frac{31}{4}$ (b) $\frac{23}{4}$ (c) $\frac{27}{4}$ (d) 0

Q26. The Fourier transform $\int_{-\infty}^{\infty} dx f(x) e^{ikx}$ of the function $f(x) = e^{-|x|}$

- (a) $-\frac{2}{1+k^2}$ (b) $-\frac{1}{2(1+k^2)}$ (c) $\frac{2}{1+k^2}$ (d) $\frac{2}{(2+k^2)}$

Q27. The value of the integral

$$\int_{-\pi/2}^{\pi/2} dx \int_{-1}^{+1} dy \delta(\sin 2x) \delta(x-y)$$
 is

- (a) 0 (b) $\frac{1}{2}$ (c) $\frac{1}{\sqrt{2}}$ (d) 1

Q28. A particle moves in the one-dimensional potential $V(x) = \alpha x^6$, where $\alpha > 0$ is a constant. If the total energy of the particle is E , its time period in a periodic motion is proportional to

- (a) $E^{-1/3}$ (b) $E^{-1/2}$ (c) $E^{1/3}$ (d) $E^{1/2}$

Q29. Two point charges $+2Q$ and $-Q$ are kept at point with Cartesian coordinates $(1,0,0)$, respectively, in front of an infinite grounded conducting plate at $x=0$. The potential at $(x,0,0)$ for $x \gg 1$ depends on x as

- (a) x^{-3} (b) x^{-5} (c) x^{-2} (d) x^{-4}

Q30. Two Stern-Gerlach apparatus S_1 and S_2 are kept in a line (x -axis). The directions of their magnetic fields are along the positive z and y -axes, respectively. Each apparatus only transmits particles with spins aligned in the direction of its magnetic field. If an initially unpolarized beam of spin $\frac{1}{2}$ particles passes through this configuration, the ratio of intensities $I_0 : I_f$ of the initial and final beams is

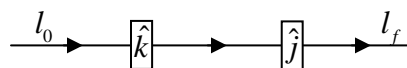

- (a) 16:1 (b) 2:1 (c) 4:1 (d) 1:0

Q31. The following configuration of three identical narrow slits are illuminated by monochromatic light of wavelength λ (as shown in the figure below). The intensity is measured at an angle θ (where θ is the angle with the incident beam) at a large distance from the slits. If $\delta = \frac{2\pi d}{\lambda} \sin \theta$, the intensity is proportional to

- (a) $2 \cos \delta + 2 \cos 2\delta$
- (b) $3 + \frac{1}{\delta^2} \sin^2 3\delta$
- (c) $3 + 2 \cos \delta + 2 \cos 2\delta + 2 \cos 3\delta$
- (d) $2 + \frac{1}{\delta^2} \sin^2 3\delta$

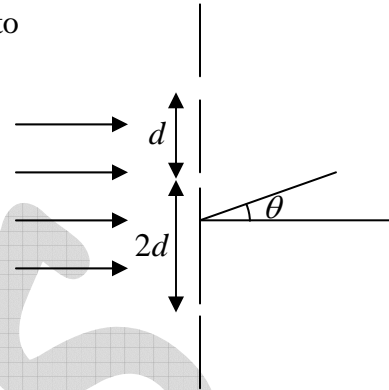

Q32. A particle of mass m , kept in potential $V(x) = -\frac{1}{2}kx^2 + \frac{1}{4}\lambda x^4$ (where k and λ are positive constants), undergoes small oscillations about an equilibrium point. The frequency of oscillations is

- (a) $\frac{1}{2\pi} \sqrt{\frac{2\lambda}{m}}$
- (b) $\frac{1}{2\pi} \sqrt{\frac{k}{m}}$
- (c) $\frac{1}{2\pi} \sqrt{\frac{2k}{m}}$
- (d) $\frac{1}{2\pi} \sqrt{\frac{\lambda}{m}}$

Q33. The Hamiltonian of a spin $\frac{1}{2}$ particle in a magnetic field \vec{B} is given by $H = -\mu \vec{B} \cdot \vec{\sigma}$, where μ is a real constant and $\vec{\sigma} = (\sigma_x, \sigma_y, \sigma_z)$ are the Pauli spin matrices. If $\vec{B} = (B_0, B_0, 0)$ and the spin state at time $t=0$ is an eigenstate of σ_x , then of the expectation values $\langle \sigma_x \rangle$, $\langle \sigma_y \rangle$ and $\langle \sigma_z \rangle$

- (a) only $\langle \sigma_x \rangle$ changes with time
- (b) only $\langle \sigma_y \rangle$ changes with time
- (c) only $\langle \sigma_z \rangle$ changes with time
- (d) all three change with time

Q34. A particle of mass m is constrained to move in a circular ring of radius R . When a perturbation $V' = \frac{a}{R^2} \cos^2 \phi$ (where a is a real constant) is added, the shift in energy of the ground state, to first order in a , is

- (a) $\frac{a}{R^2}$
- (b) $\frac{2a}{R^2}$
- (c) $\frac{a}{2R^2}$
- (d) $\frac{a}{(\pi R^2)}$

Q35. A particle of mass m is confined in a three-dimensional box by the potential

$$V(x, y, z) = \begin{cases} 0, & 0 \leq x, y, z \leq a \\ \infty & \text{otherwise} \end{cases}$$

The number of eigenstates of Hamiltonian with energy $\frac{9\hbar^2\pi^2}{2ma^2}$ is

- (a) 1 (b) 6 (c) 3 (d) 4

Q36. The electric field \vec{E} and the magnetic field \vec{B} corresponding to the scalar and vector potentials, $V(x, y, z, t) = 0$ and $\vec{A}(x, y, z, t) = \frac{1}{2}\hat{k}\mu_0 A_0(ct - x)$, where A_0 is a constant, are

- (a) $\vec{E} = 0$ and $\vec{B} = \frac{1}{2}\hat{j}\mu_0 A_0$ (b) $\vec{E} = -\frac{1}{2}\hat{k}\mu_0 A_0 c$ and $\vec{B} = \frac{1}{2}\hat{j}\mu_0 A_0$
 (c) $\vec{E} = 0$ and $\vec{B} = -\frac{1}{2}\hat{i}\mu_0 A_0$ (d) $\vec{E} = \frac{1}{2}\hat{k}\mu_0 A_0 c$ and $\vec{B} = -\frac{1}{2}\hat{i}\mu_0 A_0$

Q37. The electric field of a plane wave in a conducting medium is given by

$$\vec{E}(z, t) = \hat{i}E_0 e^{-z/3a} \cos\left(\frac{z}{\sqrt{3}a} - \omega t\right),$$

where ω is the angular frequency and $a > 0$ is a constant. The phase difference between the magnetic field \vec{B} and the electric field \vec{E} is

- (a) 30° and \vec{B} lags behind \vec{E} (b) 30° and \vec{E} lags behind \vec{B}
 (c) 60° and \vec{E} lags behind \vec{B} (d) 60° and \vec{B} lags behind \vec{E}

Q38. Which of the following statements concerning the coefficient of volume expansion α and the isothermal compressibility κ of a solid is true?

- (a) α and κ are both intensive variables
 (b) α is an intensive and κ is an extensive variable
 (c) α is an extensive and κ is an intensive variable
 (d) α and κ are both extensive variables

- Q39. A sinusoidal signal with a peak voltage V_p and average value zero, is an input to the following circuit.

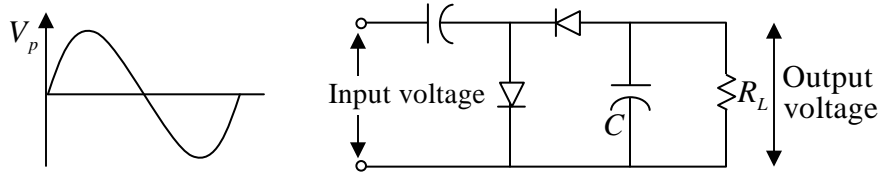

Assuming ideal diodes, the peak value of the output voltage across the load resistor R_L is

- (a) V_p (b) $\frac{V_p}{2}$ (c) $2V_p$ (d) $\sqrt{2}V_p$
- Q40. In the following circuit, the value of the common-emitter forward current amplification factor β for the transistor is 100 and V_{BE} is $0.7V$.

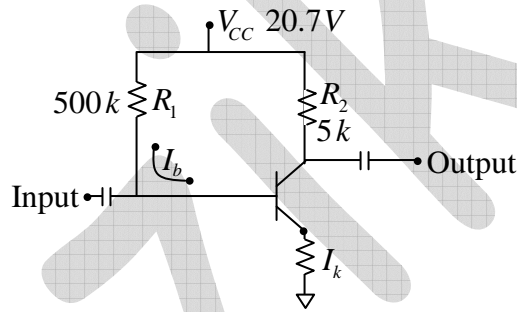

The base current I_B is

- (a) $40 \mu A$ (b) $30 \mu A$ (c) $44 \mu A$ (d) $33 \mu A$
- Q41. The number of ways of distributing 11 indistinguishable bosons in 3 different energy levels is
- (a) 3^{11} (b) 11^3 (c) $\frac{(13)!}{2!(11)!}$ (d) $\frac{(11)!}{3!8!}$

- Q42. The van der Waals equation for one mole of a gas is $\left(p + \frac{a}{V^2}\right)(V - b) = RT$. The corresponding equation of state for n moles of this gas at pressure P , volume V and temperature T , is

- (a) $\left(P + \frac{an^2}{V^2}\right)(V - nb) = nRT$ (b) $\left(P + \frac{a}{V^2}\right)(V - nb) = nRT$
- (c) $\left(P + \frac{an^2}{V^2}\right)(V - nb) = nRT$ (d) $\left(P + \frac{a}{V^2}\right)(V - nb) = nRT$

Q43. In a system of N distinguishable particles, each particle can be in one of two states with energies 0 and $-E$, respectively. The mean energy of the system at temperature T is

- (a) $-\frac{1}{2}N(1+e^{\varepsilon/k_B T})$ (b) $-NE(1+e^{\varepsilon/k_B T})$
 (c) $-\frac{1}{2}NE$ (d) $-NE(1+e^{-\varepsilon/k_B T})$

Q44. In the following JK flip-flop circuit, J and K inputs are tied together to $+V_{CC}$. If the input is a clock signal of frequency f , the frequency of the output Q is

- (a) f
 (b) $2f$
 (c) $4f$
 (d) $\frac{f}{2}$

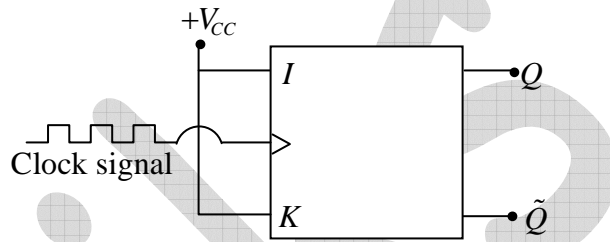

Q45. Which of the following gates can be used as a parity checker?

- (a) an OR gate (b) a NOR gate
 (c) an exclusive OR (XOR) gate (d) an AND gate

PART C

- Q46. Which of the following statements is true for a 3×3 real orthogonal matrix with determinant +1?
- (a) the modulus of each of its eigenvalues need not be 1, but their product must be 1
 (b) at least one of its eigenvalues is +1
 (c) all of its eigenvalues must be real
 (d) none of its eigenvalues must be real
- Q47. A particle of mass m moves in a central potential $V(r) = -\frac{k}{r}$ in an elliptic orbit $r(\theta) = \frac{a(1-e^2)}{1+e \cos \theta}$, where $0 \leq \theta < 2\pi$ and a and e denote the semi-major axis and eccentricity, respectively. If its total energy is $E = -\frac{k}{2a}$, the maximum kinetic energy is
- (a) $E(1-e^2)$ (b) $E \frac{(e+1)}{(e-1)}$ (c) $E/(1-e^2)$ (d) $E \frac{(e-1)}{(e+1)}$
- Q48. The Hamiltonian of a one-dimensional system is $H = \frac{xp^2}{2m} + \frac{1}{2}kx$, where m and k are positive constants. The corresponding Euler-Lagrange equation for the system is
- (a) $m\ddot{x} + k = 0$ (b) $m\ddot{x} + 2\dot{x} + kx^2 = 0$
 (c) $2m\ddot{x} - m\dot{x}^2 + kx^2 = 0$ (d) $m\ddot{x} + 2m\dot{x}^2 + kx^2 = 0$
- Q49. A hollow waveguide supports transverse electric (TE) modes with the dispersion relation $k = \frac{1}{c} \sqrt{\omega^2 - \omega_{mn}^2}$, where ω_{mn} is the mode frequency. The speed of flow of electromagnetic energy at the mode frequency is
- (a) c (b) ω_{mn} / k (c) 0 (d) ∞
- Q50. The energy of a free relativistic particle is $E = \sqrt{|\vec{p}|^2 c^2 + m^2 c^4}$, where m is its rest mass, \vec{p} is its momentum and c is the speed of light in vacuum. The ratio v_g / v_p of the group velocity v_g of a quantum mechanical wave packet (describing this particle) to the phase velocity v_p is
- (a) $|\vec{p}|c / E$ (b) $|\vec{p}|mc^3 / E^2$ (c) $|\vec{p}|^2 c^3 / E^2$ (d) $|\vec{p}|c / 2E$

Q51. In the function $P_n(x)e^{-x^2}$ of a real variable x , $P_n(x)$ is polynomial of degree n . The maximum number of extrema that this function can have is

- (a) $n+2$ (b) $n-1$ (c) $n+1$ (d) n

Q52. The Green's function $G(x, x')$ for the equation $\frac{d^2 y(x)}{dx^2} + y(x) = f(x)$, with the boundary values $y(0) = y\left(\frac{\pi}{2}\right) = 0$, is

$$(a) G(x, x') = \begin{cases} x\left(x' - \frac{\pi}{2}\right), & 0 < x < x' < \frac{\pi}{2} \\ \left(x - \frac{\pi}{2}\right)x', & 0 < x' < x < \frac{\pi}{2} \end{cases}$$

$$(b) G(x, x') = \begin{cases} -\cos x' \sin x, & 0 < x < x' < \frac{\pi}{2} \\ -\sin x' \cos x, & 0 < x' < x < \frac{\pi}{2} \end{cases}$$

$$(c) G(x, x') = \begin{cases} \cos x' \sin x, & 0 < x < x' < \frac{\pi}{2} \\ \sin x' \cos x, & 0 < x' < x < \frac{\pi}{2} \end{cases}$$

$$(d) G(x, x') = \begin{cases} x\left(\frac{\pi}{2} - x'\right), & 0 < x < x' < \frac{\pi}{2} \\ x'\left(\frac{\pi}{2} - x\right), & 0 < x' < x < \frac{\pi}{2} \end{cases}$$

Q53. The fractional error in estimating the integral $\int_0^1 x dx$ using Simpson's $\frac{1}{3}$ rule, using a step size 0.1, is nearest to

- (a) 10^{-4} (b) 0 (c) 10^{-2} (d) 3×10^{-4}

Q54. An inertial frame K' moves with a constant speed v with respect to another inertial frame K along their common x -direction. Let (x, ct) and (x', ct') denote the space-time coordinates in the frames K and K' , respectively. Which of the following space-time diagrams correctly describes the t' -axis ($x' = 0$ line) and the x' -axis ($t' = 0$ line) in the x - ct plane? (In the following figures $\tan \phi = v/c$)

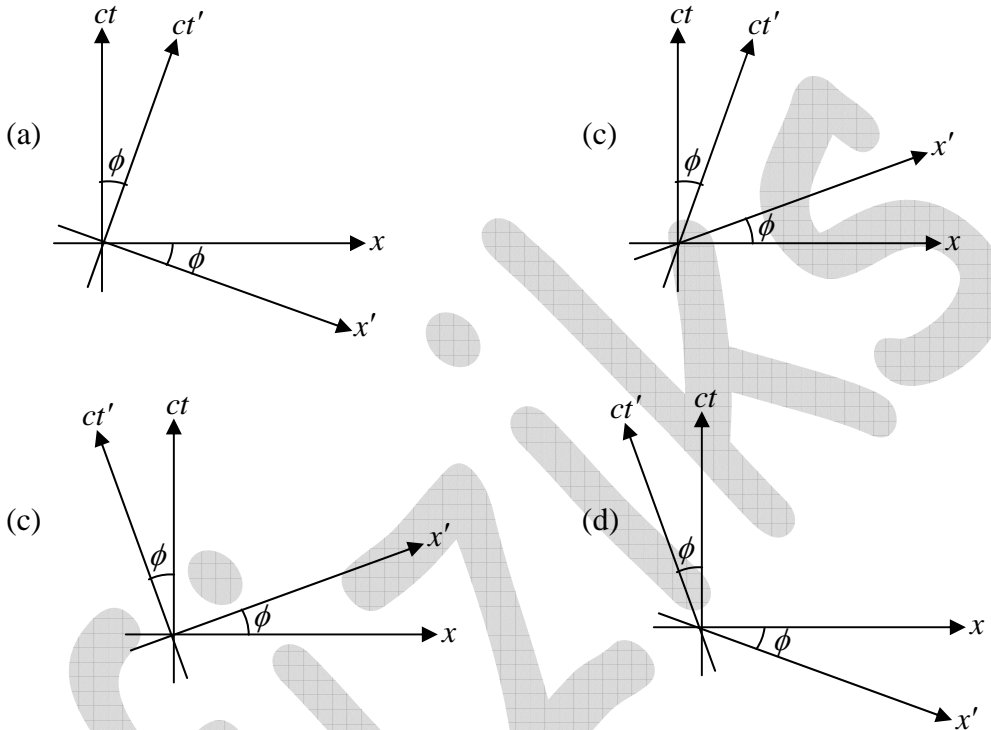

Q55. The loop shown in the figure below carries a steady current I .

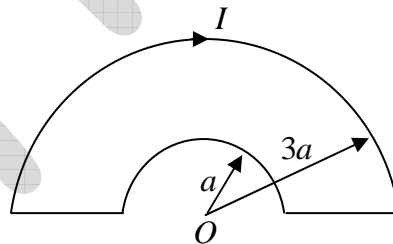

The magnitude of the magnetic field at the point O is

- (a) $\frac{\mu_0 I}{2a}$ (b) $\frac{\mu_0 I}{6a}$ (c) $\frac{\mu_0 I}{4a}$ (d) $\frac{\mu_0 I}{3a}$

Q56. In the region far from a source, the time dependent electric field at a point (r, θ, ϕ) is

$$\vec{E}(r, \theta, \phi) = \hat{\phi} E_0 \omega^2 \left(\frac{\sin \theta}{r} \right) \cos \left[\omega \left(t - \frac{r}{c} \right) \right]$$

where ω is angular frequency of the source. The total power radiated (averaged over a cycle) is

(a) $\frac{2\pi E_0^2 \omega^4}{3 \mu_0 c}$ (b) $\frac{4\pi E_0^2 \omega^4}{3 \mu_0 c}$ (c) $\frac{4 E_0^2 \omega^4}{3\pi \mu_0 c}$ (d) $\frac{2 E_0^2 \omega^4}{3 \mu_0 c}$

Q57. The pressure P of a system of N particles contained in a volume V at a temperature T is given by $P = nk_B T - \frac{1}{2} a n^2 + \frac{1}{6} b n^3$, where n is the number density and a and b are temperature independent constants. If the system exhibits a gas-liquid transition, the critical temperature is

(a) $\frac{a}{bk_B}$ (b) $\frac{a}{2b^2 k_B}$ (c) $\frac{a^2}{2bk_B}$ (d) $\frac{a^2}{b^2 k_B}$

Q58. Consider a particle diffusing in a liquid contained in a large box. The diffusion constant of the particle in the liquid is $1.0 \times 10^{-2} \text{ cm}^2 / \text{s}$. The minimum time after which the root-mean-squared displacement becomes more than 6 cm is

(a) 10 min (b) 6 min (c) 30 min (d) $\sqrt{6}$ min

Q59. A thermally insulated chamber of dimensions $(L, L, 2L)$ is partitioned in the middle. One side of the chamber is filled with n moles of an ideal gas at a pressure P and temperature T , while the other side is empty. At $t = 0$, the partition is removed and the gas is allowed to expand freely. The time to reach equilibrium varies as

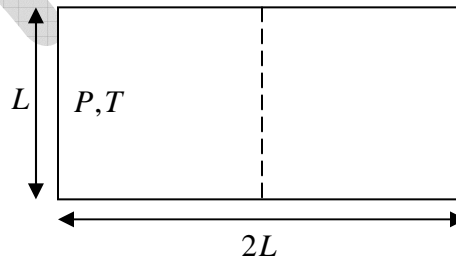

(a) $n^{1/3} L^{-1} T^{1/2}$ (b) $n^{2/3} L T^{-1/2}$ (c) $n^0 L T^{-1/2}$ (d) $n L^{-1} T^{1/2}$

Q60. Two signals $A_1 \sin(\omega t)$ and $A_2 \cos(\omega t)$ are fed into the input and the reference channels, respectively, of a lock-in amplifier. The amplitude of each signal is $1 V$. The time constant of the lock-in amplifier is such that any signal of frequency larger than ω is filtered out. The output of the lock-in amplifier is

- (a) $2 V$ (b) $1 V$ (c) $0.5 V$ (d) $0 V$

Q61. The maximum intensity of solar radiation is at the wavelength of $\lambda_{sun} \sim 5000 \text{ \AA}$ and corresponds to its surface temperature $T_{sun} \sim 10^4 K$. If the wavelength of the maximum intensity of an X -ray star is 5 \AA , its surface temperature is of the order of

- (a) $10^{16} K$ (b) $10^{14} K$ (c) $10^{10} K$ (d) $10^7 K$

Q62. The full scale of a 3-bit digital-to-analog (DAC) converter is $7V$. Which of the following tables represents the output voltage of this 3-bit DAC for the given set of input bits?

(a)

Input bits	Output voltage
000	0
001	1
010	2
011	3

(b)

Input bits	Output voltage
000	0
001	1.25
010	2.5
011	3.75

(c)

Input bits	Output voltage
000	1.25
001	2.5
010	3.75
011	5

(d)

Input bits	Output voltage
000	1
001	2
010	3
011	4

Q63. The input V_i to the following circuit is a square wave as shown in the following figure

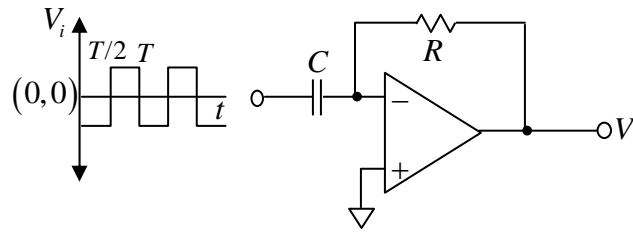

Which of the waveforms V_o best describes the output?

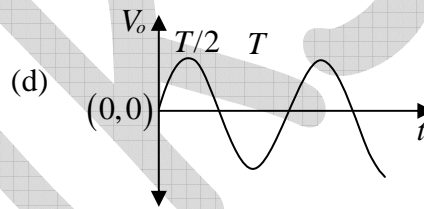
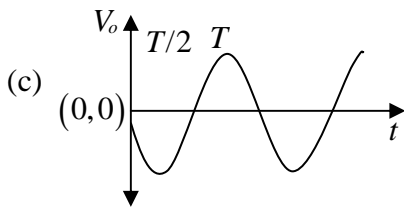
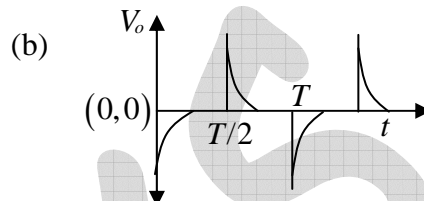
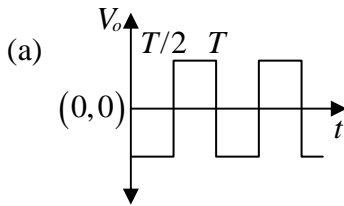

Q64. The n^{th} energy eigenvalues E_n of a one-dimensional Hamiltonian $H = \frac{p^2}{2m} + \lambda x^4$ (where

$\lambda > 0$ is a constant) in the WEB approximation, is proportional to

(a) $\left(n + \frac{1}{2}\right)^{4/3} \lambda^{1/3}$ (b) $\left(n + \frac{1}{2}\right)^{4/3} \lambda^{2/3}$

(c) $\left(n + \frac{1}{2}\right)^{5/3} \lambda^{1/3}$ (d) $\left(n + \frac{1}{2}\right)^{5/3} \lambda^{2/3}$

Q65. The differential scattering cross-section $\frac{d\sigma}{d\Omega}$ for the central potential $V(r) = \frac{\beta}{r} e^{-\mu r}$,

where β and μ are positive constants, is calculated in the first Born approximation. Its dependence on the scattering angle θ is proportional to (A is a constant below)

(a) $\left(A^2 + \sin^2 \frac{\theta}{2}\right)$ (b) $\left(A^2 + \sin^2 \frac{\theta}{2}\right)^{-1}$

(c) $\left(A^2 + \sin^2 \frac{\theta}{2}\right)^{-2}$ (d) $\left(A^2 + \sin^2 \frac{\theta}{2}\right)^2$

Q66. At $t=0$, the wavefunction of an otherwise free particle confined between two infinite walls at $x=0$ and $x=L$ is $\psi(x, t=0) = \sqrt{\frac{2}{L}} \left(\sin \frac{\pi x}{L} - \sin \frac{3\pi x}{L} \right)$. Its wave function at a

later time $t = \frac{mL^2}{4\pi\hbar}$ is

- (a) $\sqrt{\frac{2}{L}} \left(\sin \frac{\pi x}{L} - \sin \frac{3\pi x}{L} \right) e^{i\pi/6}$ (b) $\sqrt{\frac{2}{L}} \left(\sin \frac{\pi x}{L} + \sin \frac{3\pi x}{L} \right) e^{-i\pi/6}$
 (c) $\sqrt{\frac{2}{L}} \left(\sin \frac{\pi x}{L} - \sin \frac{3\pi x}{L} \right) e^{-i\pi/8}$ (d) $\sqrt{\frac{2}{L}} \left(\sin \frac{\pi x}{L} + \sin \frac{3\pi x}{L} \right) e^{-i\pi/6}$

Q67. Sodium Chloride ($NaCl$) crystal is a face-centered cubic lattice with a basis consisting of Na^+ and Cl^- ions separated by half the body diagonal of a unit cube. Which of the planes corresponding to the Miller indices given below will not give rise to Bragg reflection of X -rays?

- (a) (220) (b) (242) (c) (221) (d) (311)

Q68. The dispersion relation for the electrons in the conduction band of a semiconductor is given by $E = E_0 + \alpha k^2$ where α and E_0 are constants. If ω_c is the cyclotron resonance frequency of the conduction band electrons in a magnetic field B , the value of α is

- (a) $\frac{\hbar\omega_c}{4eB}$ (b) $\frac{2\hbar^2\omega_c}{eB}$ (c) $\frac{\hbar^2\omega_c}{eB}$ (d) $\frac{\hbar^2\omega_c}{2eB}$

Q69. Hard disc of radius R are arranged in a two-dimensional triangular lattice. What is the fractional area occupied by the discs in the closest possible packing?

- (a) $\frac{\pi\sqrt{3}}{6}$ (b) $\frac{\pi}{3\sqrt{2}}$ (c) $\frac{\pi\sqrt{2}}{5}$ (d) $\frac{2\pi}{7}$

Q70. A photon of energy 115.62 keV ionizes a K -shell electron of a Be atom. One L -shell electron jumps to the K -shell to fill this vacancy and emits a photon of energy 109.2 keV in the process. If the ionization potential for the L -shell is 6.4 keV , the kinetic energy of the ionized electron is

- (a) 6.42 keV (b) 12.82 keV (c) 20 eV (d) 32 eV

Q71. The value of the Lande g -factor for a fine-structure level defined by the quantum number $L=1, J=2$ and $S=1$, is

- (a) $\frac{11}{6}$ (b) $\frac{4}{3}$ (c) $\frac{8}{3}$ (d) $\frac{3}{2}$

Q72. The electronic energy level diagram of a molecule is shown in the following figure,

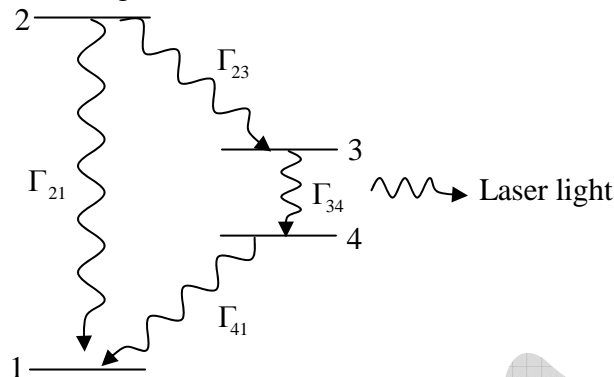

Let Γ_{ij} denote the decay rate for a transition from the level i to j . The molecules are optically pumped from level 1 to 2. For the transition from level 3 to level 4 to be a lassing transition, the decay rates have to satisfy

- (a) $\Gamma_{21} > \Gamma_{23} > \Gamma_{41} > \Gamma_{34}$ (b) $\Gamma_{21} > \Gamma_{41} > \Gamma_{23} > \Gamma_{34}$
 (c) $\Gamma_{41} > \Gamma_{23} > \Gamma_{21} > \Gamma_{34}$ (d) $\Gamma_{41} > \Gamma_{21} > \Gamma_{34} > \Gamma_{23}$

Q73. The reaction ${}^{63}\text{Cu}_{29} + p \rightarrow {}^{63}\text{Zn}_{30} + n$ is followed by a prompt β -decay of zinc ${}^{63}\text{Zn}_{30} \rightarrow {}^{63}\text{Cu}_{29} + e^+ + \nu_e$. If the maximum energy of the positron is 2.4 MeV , the Q -value of the original reaction in MeV is nearest to

[Take the masses of electron, proton and neutron to be $0.5 \text{ MeV}/c^2$, $938 \text{ MeV}/c^2$ and $939.5 \text{ MeV}/c^2$, respectively.]

- (a) -4.4 (b) -2.4 (c) -4.8 (d) -3.4

Q74. A deuteron d captures a charged pion π^- in the $l = 1$ state, and subsequently decays into a pair of neutrons (n) via strong interaction. Given that the intrinsic parities of π^- , d and n are $-1, +1$ and $+1$ respectively, the spin wavefunction of the final state neutrons is

- (a) linear combination of a singlet and a triplet
 (b) singlet
 (c) triplet
 (d) doublet

Q75. Which of the following elementary particle processes does not conserve strangeness?

- (a) $\pi^0 + p \rightarrow k^+ + \Lambda^0$ (b) $\pi^- + p \rightarrow k^0 + \Lambda^0$
 (c) $\Delta^0 \rightarrow \pi^0 + n$ (d) $K^0 \rightarrow \pi^+ + \pi^-$