

NET JUNE 2016

PART A

- Q1. An infinite number of identical circular discs each of radius $\frac{1}{2}$ are tightly packed such that the centers of the discs are at integer values of coordinates x and y . The ratio of the area of the uncovered patches to the total area is
- (a) $1 - \frac{\pi}{4}$ (b) $\frac{\pi}{4}$ (c) $1 - \pi$ (d) π
- Q2. It takes 5 days for a steamboat to travel from A to B along a river. It takes 7 days to return from B to A . How many days will it take for a raft to drift from A to B (all speeds stay constant)?
- (a) 13 (b) 35 (c) 6 (d) 12
- Q3. “My friend Raju has more than 1000 books” said Ram “Oh no, he has less than 1000 books”, said Shyam. “Well Raju certainly has at least one book” said Geeta. If only one of these statements is true, how many books does Raju have?
- (a) 1 (b) 1000 (c) 999 (d) 1001
- Q4. Of the following, which is the odd one out?
- (a) Cone (b) Torus (c) Sphere (d) Ellipsoid
- Q5. A student appearing for an exam is declared to have failed the exam if his/her score is less than half the median score. This implies
- (a) $\frac{1}{4}$ of the students appearing for the exam always fail.
- (b) if a student scores less than $\frac{1}{4}$ of the maximum score, he/she always fails.
- (c) if a student score more than $\frac{1}{2}$ of the maximum score, he/she always passes
- (d) it is possible that no one fails

Head office

fiziks, H.No. 40 D, G.F, Jia Sarai,
Near IIT, Hauz Khas, New Delhi-16
Phone: 011-26865455/+91-9871145498

Branch office

Anand Institute of Mathematics,
28-B/6, Jia Sarai, Near IIT
Hauz Khas, New Delhi-16

Q6. Find the next figure "D"

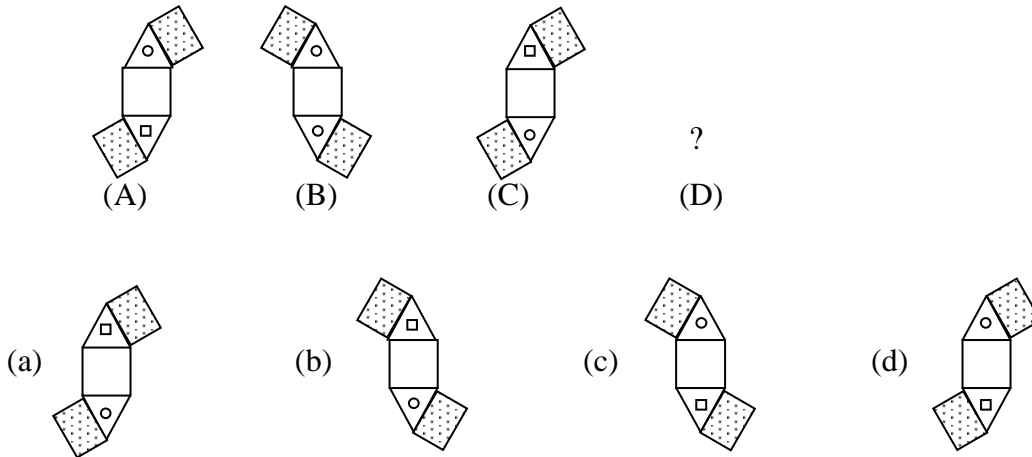

Q7. N is a four digit number. If the leftmost digit is removed, the resulting three digit number is $\frac{1}{9}$ th of N . How many such N are possible?

- (a) 10 (b) 9 (c) 8 (d) 7

Q8. AB and CD are two chords of a circle subtending 60° and 120° respectively at the same point on the circumference of the circle. Then $AB : CD$ is

- (a) $\sqrt{3} : 1$ (b) $\sqrt{2} : 1$ (c) $1 : 1$ (d) $\sqrt{3} : \sqrt{2}$

Q9.

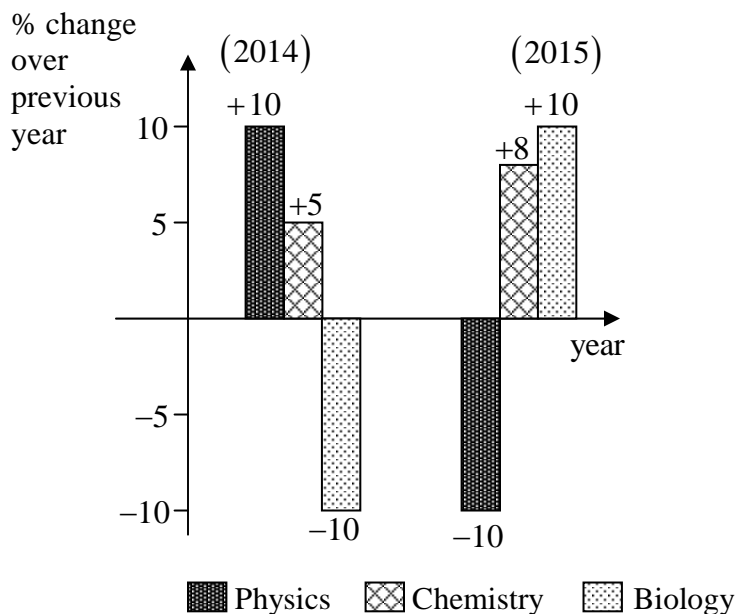

Head office

fiziks, H.No. 40 D, G.F, Jia Sarai,
Near IIT, Hauz Khas, New Delhi-16
Phone: 011-26865455/+91-9871145498

Branch office

Anand Institute of Mathematics,
28-B/6, Jia Sarai, Near IIT
Hauz Khas, New Delhi-16

Which of the following inferences can be drawn from the above graph?

- (a) The total number of students qualifying in physics in 2015 and 2014 is the same
- (b) The number of students qualifying in Biology in 2015 is less than in 2013
- (c) The number of Chemistry students qualifying in 2015 must be more than the number of students who qualified in Biology in 2014
- (d) The number of students qualifying in physics in 2015 is equal to the number of students in Biology that qualified in 2014

Q10. What is the minimum number of moves required to transform figure 1 to figure 2? A move is defined as removing a coin and placing it such that it touches two other coins in its new position

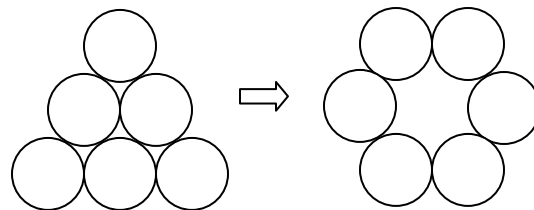
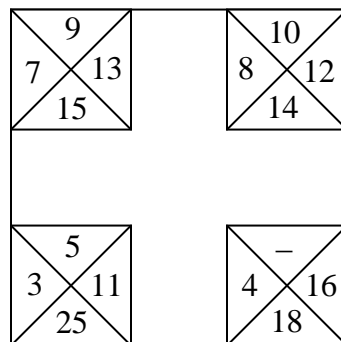

Fig -1

Fig -2

- (a) 1
- (b) 2
- (c) 3
- (d) 4

Q11. The relationship among the numbers in each corner square is the same as that in the other corner squares. Find the missing number.



- (a) 10
- (b) 8
- (c) 6
- (d) 12

Q12. Which of the following best approximates $\sin(0.5^\circ)$?

- (a) 0.5
- (b) $0.5 \times \frac{\pi}{90}$
- (c) $0.5 \times \frac{\pi}{180}$
- (d) $0.5 \times \frac{\pi}{360}$

Head office

fiziks, H.No. 40 D, G.F, Jia Sarai,
Near IIT, Hauz Khas, New Delhi-16
Phone: 011-26865455/+91-9871145498

Branch office

Anand Institute of Mathematics,
28-B/6, Jia Sarai, Near IIT
Hauz Khas, New Delhi-16

Q13. What comes next in the sequence?



- (a) (b) (c) (d)

Q14. Which of the following statements is logically incorrect?

- (a) I always speak the truth
 (b) I occasionally lie
 (c) I occasionally speak the truth
 (d) I always lie

Q15. How many times starting at 1.00 pm would the minute and hour hands of a clock make an angle of 40° with each other in the next 6 hours?

- (a) 6 (b) 7 (c) 11 (d) 12

Q16. Brother Santa and Chris walk to school from their house. The former takes 40 minutes while the latter, 30 minutes. One day Santa started 5 minutes earlier than Chris. In how many minutes would Chris overtake Santa?

- (a) 5 (b) 15 (c) 20 (d) 25

Q17. The set of numbers $(5, 6, 7, m, 6, 7, 8, n)$ has an arithmetic mean of 6 and mode (most frequently occurring number) of 7. Then $m \times n =$

- (a) 18 (b) 35 (c) 28 (d) 14

Q18. The diagram shows a block of marble having the shape of a triangular prism. What is the maximum number of slabs of $10 \times 10 \times 5 \text{ cm}^3$ size that can be cut parallel to the face on which the block is resting?

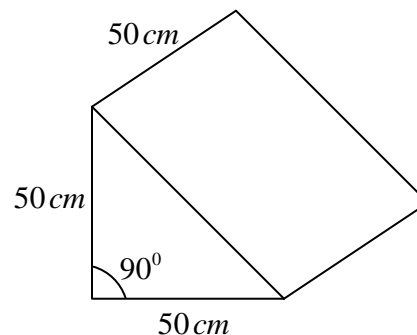

- (a) 50 (b) 100
 (c) 125 (d) 250

Head office

fiziks, H.No. 40 D, G.F, Jia Sarai,
 Near IIT, Hauz Khas, New Delhi-16
 Phone: 011-26865455/+91-9871145498

Branch office

Anand Institute of Mathematics,
 28-B/6, Jia Sarai, Near IIT
 Hauz Khas, New Delhi-16

Q19. A solid contains a spherical cavity. The cavity is filled with a liquid and includes a spherical bubble of gas. The radii of cavity and gas bubble are 2 mm and 1 mm , respectively. What proportion of the cavity is filled with liquid?

- (a) $\frac{1}{8}$ (b) $\frac{3}{8}$ (c) $\frac{5}{8}$ (d) $\frac{7}{8}$

Q20. Fill in the blank: $F2, \underline{\hspace{1cm}}, D8, C16, B32, A64$

- (a) $C4$ (b) $E4$ (c) $C2$ (d) $G16$

Head office

fiziks, H.No. 40 D, G.F, Jia Sarai,
Near IIT, Hauz Khas, New Delhi-16
Phone: 011-26865455/+91-9871145498

Branch office

Anand Institute of Mathematics,
28-B/6, Jia Sarai, Near IIT
Hauz Khas, New Delhi-16

PART-B

Q21. The radius of convergence of the Taylor series expansion of the function $\frac{1}{\cosh(x)}$ around $x = 0$, is

- (a) ∞ (b) π (c) $\frac{\pi}{2}$ (d) 1

Q22. The value of the contour integral $\frac{1}{2\pi i} \oint_C \frac{e^{4z} - 1}{\cosh(z) - 2\sinh(z)} dz$ around the unit circle C traversed in the anti-clockwise direction, is

- (a) 0 (b) 2 (c) $\frac{-8}{\sqrt{3}}$ (d) $-\tanh\left(\frac{1}{2}\right)$

Q23. The Gauss hypergeometric function $F(a, b, c, z)$, defined by the Taylor series expansion around $z = 0$ as $F(a, b, c, z) =$

$$\sum_{n=0}^{\infty} \frac{a(a+1)\dots(a+n-1)b(b+1)\dots(b+n-1)}{c(c+1)\dots(c+n-1)n!} z^n,$$

satisfies the recursion relation

- (a) $\frac{d}{dz} F(a, b, c; z) = \frac{c}{ab} F(a-1, b-1, c-1; z)$
 (b) $\frac{d}{dz} F(a, b, c; z) = \frac{c}{ab} F(a+1, b+1, c+1; z)$
 (c) $\frac{d}{dz} F(a, b, c; z) = \frac{ab}{c} F(a-1, b-1, c-1; z)$
 (d) $\frac{d}{dz} F(a, b, c; z) = \frac{ab}{c} F(a+1, b+1, c+1; z)$

Head office

fiziks, H.No. 40 D, G.F, Jia Sarai,
Near IIT, Hauz Khas, New Delhi-16
Phone: 011-26865455/+91-9871145498

Branch office

Anand Institute of Mathematics,
28-B/6, Jia Sarai, Near IIT
Hauz Khas, New Delhi-16

Q24. Let X and Y be two independent random variables, each of which follow a normal distribution with the same standard deviation σ , but with means $+\mu$ and $-\mu$, respectively. Then the sum $X + Y$ follows a

- (a) distribution with two peaks at $\pm\mu$ and mean 0 and standard deviation $\sigma\sqrt{2}$
 (b) normal distribution with mean 0 and standard deviation 2σ
 (c) distribution with two peaks at $\pm\mu$ and mean 0 and standard deviation 2σ
 (d) normal distribution with mean 0 and standard deviation $\sigma\sqrt{2}$

Q25. Using dimensional analysis, Planck defined a characteristic temperature T_p from powers of the gravitational constant G , Planck's constant h , Boltzmann constant k_B and the speed of light c in vacuum. The expression for T_p is proportional to

- (a) $\sqrt{\frac{hc^5}{k_B^2 G}}$ (b) $\sqrt{\frac{hc^3}{k_B^2 G}}$ (c) $\sqrt{\frac{G}{hc^4 k_B^2}}$ (d) $\sqrt{\frac{hk_B^2}{Gc^3}}$

Q26. Let (x, t) and (x', t') be the coordinate systems used by the observers O and O' , respectively. Observer O' moves with a velocity $v = \beta c$ along their common positive x -axis. If $x_+ = x + ct$ and $x_- = x - ct$ are the linear combinations of the coordinates, the Lorentz transformation relating O and O' takes the form

- (a) $x'_+ = \frac{x_- - \beta x_+}{\sqrt{1 - \beta^2}}$ and $x'_- = \frac{x_+ - \beta x_-}{\sqrt{1 - \beta^2}}$ (b) $x'_+ = \sqrt{\frac{1 + \beta}{1 - \beta}} x_+$ and $x'_- = \sqrt{\frac{1 - \beta}{1 + \beta}} x_-$
 (c) $x'_+ = \frac{x_+ - \beta x_-}{\sqrt{1 - \beta^2}}$ and $x'_- = \frac{x_- - \beta x_+}{\sqrt{1 - \beta^2}}$ (d) $x'_+ = \sqrt{\frac{1 - \beta}{1 + \beta}} x_+$ and $x'_- = \sqrt{\frac{1 + \beta}{1 - \beta}} x_-$

Q27. A ball of mass m , initially at rest, is dropped from a height of 5 meters. If the coefficient of restitution is 0.9, the speed of the ball just before it hits the floor the second time is approximately (take $g = 9.8 \text{ m/s}^2$)

- (a) 9.80 m/s (b) 9.10 m/s (c) 8.91 m/s (d) 7.02 m/s

Head office

fiziks, H.No. 40 D, G.F, Jia Sarai,
 Near IIT, Hauz Khas, New Delhi-16
 Phone: 011-26865455/+91-9871145498

Branch office

Anand Institute of Mathematics,
 28-B/6, Jia Sarai, Near IIT
 Hauz Khas, New Delhi-16

Q28. Four equal charges of $+Q$ each are kept at the vertices of a square of side R . A particle of mass m and charge $+Q$ is placed in the plane of the square at a short distance a ($\ll R$) from the centre. If the motion of the particle is confined to the plane, it will undergo small oscillations with an angular frequency

(a) $\sqrt{\frac{Q^2}{2\pi\epsilon_0 R^3 m}}$

(b) $\sqrt{\frac{Q^2}{\pi\epsilon_0 R^3 m}}$

(c) $\sqrt{\frac{\sqrt{2}Q^2}{\pi\epsilon_0 R^3 m}}$

(d) $\sqrt{\frac{Q^2}{4\pi\epsilon_0 R^3 m}}$

Q29. The Hamiltonian of a system with generalized coordinate and momentum (q, p) is $H = p^2 q^2$. A solution of the Hamiltonian equation of motion is (in the following A and B are constants)

(a) $p = Be^{-2At}$, $q = \frac{A}{B}e^{2At}$

(b) $p = Ae^{-2At}$, $q = \frac{A}{B}e^{-2At}$

(c) $p = Ae^{At}$, $q = \frac{A}{B}e^{-At}$

(d) $p = 2Ae^{-A^2t}$, $q = \frac{A}{B}e^{A^2t}$

Q30. Two parallel plate capacitors, separated by distances x and $1.1x$ respectively, have a dielectric material of dielectric constant 3.0 inserted between the plates and are connected to a battery of voltage V . The difference in charge on the second capacitor compared to the first is

(a) +66%

(b) +20%

(c) -3.3%

(d) -10%

Q31. The half space region $x > 0$ and $x < 0$ are filled with dielectric media of dielectric constants ϵ_1 and ϵ_2 respectively. There is a uniform electric field in each part. In the right half, the electric field makes an angle θ_1 to the interface. The corresponding angle θ_2 in the left half satisfies

(a) $\epsilon_1 \sin \theta_2 = \epsilon_2 \sin \theta_1$

(b) $\epsilon_1 \tan \theta_2 = \epsilon_2 \tan \theta_1$

(c) $\epsilon_1 \tan \theta_1 = \epsilon_2 \tan \theta_2$

(d) $\epsilon_1 \sin \theta_1 = \epsilon_2 \sin \theta_2$

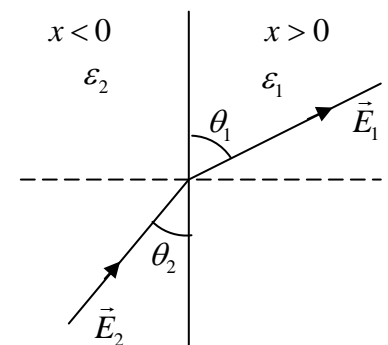

Head office

fiziks, H.No. 40 D, G.F, Jia Sarai,
Near IIT, Hauz Khas, New Delhi-16
Phone: 011-26865455/+91-9871145498

Branch office

Anand Institute of Mathematics,
28-B/6, Jia Sarai, Near IIT
Hauz Khas, New Delhi-16

Q32. The x - and z -components of a static magnetic field in a region are $B_x = B_0(x^2 - y^2)$ and $B_z = 0$, respectively. Which of the following solutions for its y -component is consistent with the Maxwell equations?

- (a) $B_y = B_0xy$ (b) $B_y = -2B_0xy$
 (c) $B_y = -B_0(x^2 - y^2)$ (d) $B_y = B_0\left(\frac{1}{3}x^3 - xy^2\right)$

Q33. A magnetic field B is $B\hat{z}$ in the region $x > 0$ and zero elsewhere. A rectangular loop, in the xy -plane, of sides l (along the x -direction) and h (along the y -direction) is inserted into the $x > 0$ region from the $x < 0$ region at constant velocity $v = v\hat{x}$. Which of the following values of l and h will generate the largest EMF?

- (a) $l = 8, h = 3$ (b) $l = 4, h = 6$
 (c) $l = 6, h = 4$ (d) $l = 12, h = 2$

Q34. The state of a particle of mass m in a one dimensional rigid box in the interval 0 to L is given by the normalized wavefunction $\psi(x) = \sqrt{\frac{2}{L}}\left(\frac{3}{5}\sin\left(\frac{2\pi x}{L}\right) + \frac{4}{5}\sin\left(\frac{4\pi x}{L}\right)\right)$. If its energy is measured the possible outcomes and the average value of energy are, respectively

- (a) $\frac{h^2}{2mL^2}, \frac{2h^2}{mL^2}$ and $\frac{73}{50} \frac{h^2}{mL^2}$ (b) $\frac{h^2}{8mL^2}, \frac{h^2}{2mL^2}$ and $\frac{19}{40} \frac{h^2}{mL^2}$
 (c) $\frac{h^2}{2mL^2}, \frac{2h^2}{mL^2}$ and $\frac{19}{10} \frac{h^2}{mL^2}$ (d) $\frac{h^2}{8mL^2}, \frac{2h^2}{mL^2}$ and $\frac{73}{200} \frac{h^2}{mL^2}$

Q35. If $\hat{L}_x, \hat{L}_y, \hat{L}_z$ are the components of the angular momentum operator in three dimensions the commutator $[\hat{L}_x, \hat{L}_x \hat{L}_y \hat{L}_z]$ may be simplified to

- (a) $i\hbar L_x(\hat{L}_z^2 - \hat{L}_y^2)$ (b) $i\hbar \hat{L}_z \hat{L}_y \hat{L}_x$
 (c) $i\hbar L_x(2\hat{L}_z^2 - \hat{L}_y^2)$ (d) 0

Head office

fiziks, H.No. 40 D, G.F, Jia Sarai,
 Near IIT, Hauz Khas, New Delhi-16
 Phone: 011-26865455/+91-9871145498

Branch office

Anand Institute of Mathematics,
 28-B/6, Jia Sarai, Near IIT
 Hauz Khas, New Delhi-16

- Q36. Suppose that the Coulomb potential of the hydrogen atom is changed by adding an inverse-square term such that the total potential is $V(\vec{r}) = -\frac{Ze^2}{r} + \frac{g}{r^2}$, where g is a constant. The energy eigenvalues E_{nlm} in the modified potential
- depend on n and l , but not on m
 - depend on n but not on l and m
 - depend on n and m , but not on l
 - depend explicitly on all three quantum numbers n , l and m
- Q37. The eigenstates corresponding to eigenvalues E_1 and E_2 of a time independent Hamiltonian are $|1\rangle$ and $|2\rangle$ respectively. If at $t=0$, the system is in a state $|\psi(t=0)\rangle = \sin\theta|1\rangle + \cos\theta|2\rangle$ the value of $\langle\psi(t)|\psi(t)\rangle$ at time t will be
- 1
 - $\frac{(E_1 \sin^2 \theta + E_2 \cos^2 \theta)}{\sqrt{E_1^2 + E_2^2}}$
 - $e^{iE_1 t/\hbar} \sin \theta + e^{iE_2 t/\hbar} \cos \theta$
 - $e^{-iE_1 t/\hbar} \sin^2 \theta + e^{-iE_2 t/\hbar} \cos^2 \theta$
- Q38. The specific heat per molecule of a gas of diatomic molecules at high temperatures is
- $8k_B$
 - $3.5k_B$
 - $4.5k_B$
 - $3k_B$
- Q39. When an ideal monatomic gas is expanded adiabatically from an initial volume V_0 to $3V_0$, its temperature changes from T_0 to T . Then the ratio $\frac{T}{T_0}$ is
- $\frac{1}{3}$
 - $\left(\frac{1}{3}\right)^{\frac{2}{3}}$
 - $\left(\frac{1}{3}\right)^{\frac{1}{3}}$
 - 3
- Q40. A box of volume V containing N molecules of an ideal gas, is divided by a wall with a hole into two compartments. If the volume of the smaller compartment is $\frac{V}{3}$, the variance of the number of particles in it, is
- $\frac{N}{3}$
 - $\frac{2N}{9}$
 - \sqrt{N}
 - $\frac{\sqrt{N}}{3}$

Head office

fiziks, H.No. 40 D, G.F, Jia Sarai,
Near IIT, Hauz Khas, New Delhi-16
Phone: 011-26865455/+91-9871145498

Branch office

Anand Institute of Mathematics,
28-B/6, Jia Sarai, Near IIT
Hauz Khas, New Delhi-16

Q41. A gas of non-relativistic classical particles in one dimension is subjected to a potential

$$V(x) = \alpha |x| \quad (\text{where } \alpha \text{ is a constant}). \quad \text{The partition function is } \left(\beta = \frac{1}{k_B T} \right)$$

- (a) $\sqrt{\frac{4m\pi}{\beta^3 \alpha^2 \hbar^2}}$ (b) $\sqrt{\frac{2m\pi}{\beta^3 \alpha^2 \hbar^2}}$ (c) $\sqrt{\frac{8m\pi}{\beta^3 \alpha^2 \hbar^2}}$ (d) $\sqrt{\frac{3m\pi}{\beta^3 \alpha^2 \hbar^2}}$

Q42. The dependence of current I on the voltage V of a certain device is given by

$$I = I_0 \left(1 - \frac{V}{V_0} \right)^2$$

where I_0 and V_0 are constants. In an experiment the current I is measured as the voltage V applied across the device is increased. The parameters V_0 and $\sqrt{I_0}$ can be graphically determined as

- (a) the slope and the y -intercept of the $I - V^2$ graph
 (b) the negative of the ratio of the y -intercept and the slope, and the y -intercept of the $I - V^2$ graph
 (c) the slope and the y -intercept of the $\sqrt{I} - V$ graph
 (d) the negative of the ratio of the y -intercept and the slope, and the y -intercept of the $\sqrt{I} - V$ graph

Q43. In the schematic figure given below, assume that the propagation delay of each logic gate is t_{gate} .

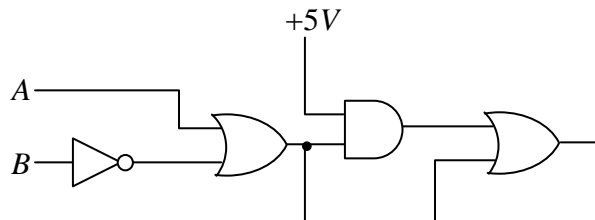

The propagation delay of the circuit will be maximum when the logic inputs A and B make the transition

- (a) $(0,1) \rightarrow (1,1)$ (b) $(1,1) \rightarrow (0,1)$
 (c) $(0,0) \rightarrow (1,1)$ (d) $(0,0) \rightarrow (0,1)$

Head office

fiziks, H.No. 40 D, G.F, Jia Sarai,
 Near IIT, Hauz Khas, New Delhi-16
 Phone: 011-26865455/+91-9871145498

Branch office

Anand Institute of Mathematics,
 28-B/6, Jia Sarai, Near IIT
 Hauz Khas, New Delhi-16

Q44. Given the input voltage V_i , which of the following waveforms correctly represents the output voltage V_o in the circuit shown below?

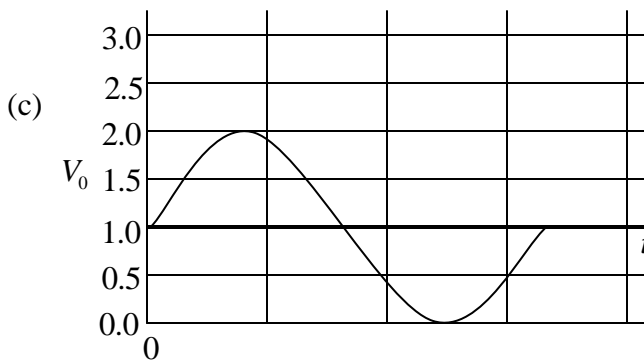
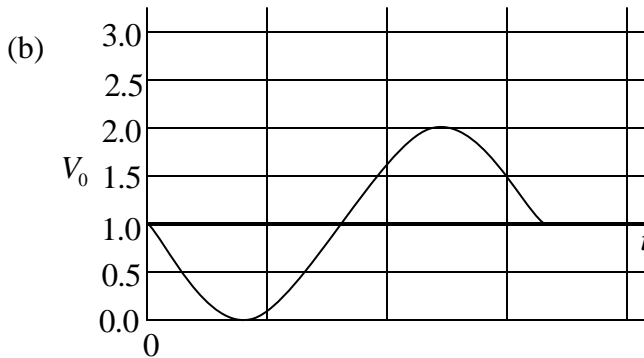
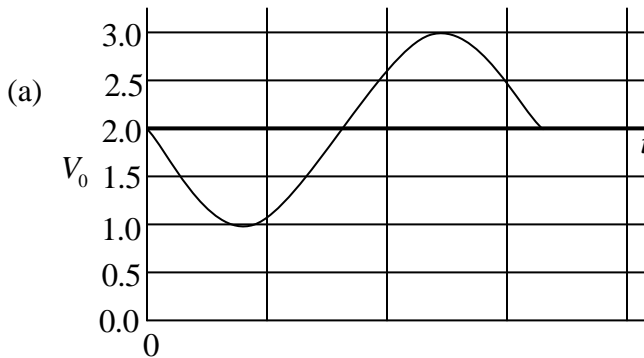
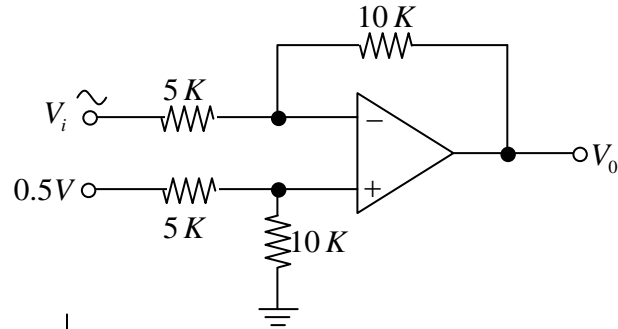
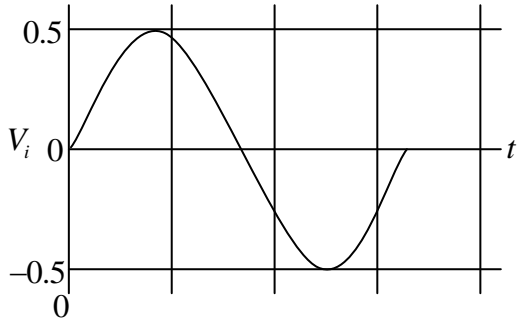

Head office

fiziks, H.No. 40 D, G.F, Jia Sarai,
Near IIT, Hauz Khas, New Delhi-16
Phone: 011-26865455/+91-9871145498

Branch office

Anand Institute of Mathematics,
28-B/6, Jia Sarai, Near IIT
Hauz Khas, New Delhi-16

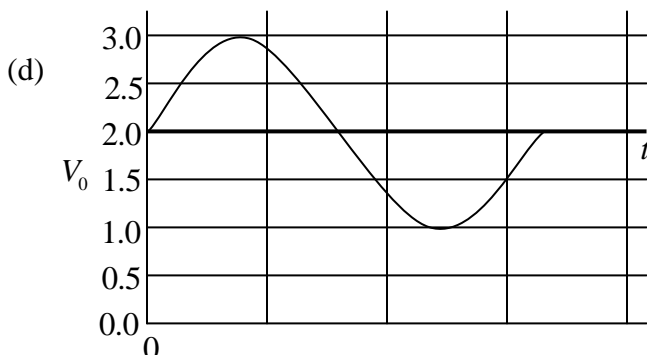

- Q45. The intensity distribution of a red *LED* on an absorbing layer of material is a Gaussian centred at the wavelength $\lambda_0 = 660 \text{ nm}$ and width 20 nm . If the absorption coefficient varies with wavelength as $\alpha_0 - K(\lambda - \lambda_0)$, where α_0 and K are positive constants, the light emerging from the absorber will be
- blue shifted retaining the Gaussian intensity distribution
 - blue shifted with an asymmetric intensity distribution
 - red shifted retaining the Gaussian intensity distribution
 - red shifted with an asymmetric intensity distribution

Head office

fiziks, H.No. 40 D, G.F, Jia Sarai,
Near IIT, Hauz Khas, New Delhi-16
Phone: 011-26865455/+91-9871145498

Branch office

Anand Institute of Mathematics,
28-B/6, Jia Sarai, Near IIT
Hauz Khas, New Delhi-16

PART-C

Q46. What is the Fourier transform $\int dx e^{ikx} f(x)$ of

$$f(x) = \delta(x) + \sum_{n=1}^{\infty} \frac{d^n}{dx^n} \delta(x)$$

where $\delta(x)$ is the Dirac delta-function?

- (a) $\frac{1}{1-ik}$ (b) $\frac{1}{1+ik}$ (c) $\frac{1}{k+i}$ (d) $\frac{1}{k-i}$

Q47. The integral equation

$$\phi(x, t) = \lambda \int dx' dt' \int \frac{d\omega dk}{(2\pi)^2} \frac{e^{ik(x-x') + i\omega(t-t')}}{\omega^2 - k^2 - m^2 + i\epsilon} \phi^3(x', t')$$

is equivalent to the differential equation

- (a) $\left(\frac{\partial^2}{\partial t^2} + \frac{\partial^2}{\partial x^2} - m^2 + i\epsilon \right) \phi(x, t) = -\frac{1}{6} \lambda \phi^3(x, t)$
 (b) $\left(\frac{\partial^2}{\partial t^2} - \frac{\partial^2}{\partial x^2} + m^2 - i\epsilon \right) \phi(x, t) = \lambda \phi^2(x, t)$
 (c) $\left(\frac{\partial^2}{\partial t^2} - \frac{\partial^2}{\partial x^2} + m^2 - i\epsilon \right) \phi(x, t) = -3\lambda \phi^2(x, t)$
 (d) $\left(\frac{\partial^2}{\partial t^2} - \frac{\partial^2}{\partial x^2} + m^2 - i\epsilon \right) \phi(x, t) = -\lambda \phi^3(x, t)$

Head office

fiziks, H.No. 40 D, G.F, Jia Sarai,
Near IIT, Hauz Khas, New Delhi-16
Phone: 011-26865455/+91-9871145498

Branch office

Anand Institute of Mathematics,
28-B/6, Jia Sarai, Near IIT
Hauz Khas, New Delhi-16

- Q48. A part of the group multiplication table for a six element group $G = \{e, a, b, c, d, f\}$ is shown below. (In the following e is the identity element of G)

| | | | | | | |
|---|---|---|---|---|---|---|
| | e | a | B | c | d | f |
| e | e | a | B | c | d | f |
| a | a | b | E | d | | |
| b | b | e | X | f | y | z |
| c | c | | | | | |
| d | d | | | | | |
| f | f | | | | | |

The entries x, y and z should be

- (a) $x = a, y = d$ and $z = c$ (b) $x = c, y = a$ and $z = d$
 (c) $x = c, y = d$ and $z = a$ (d) $x = a, y = c$ and $z = d$
- Q49. In finding the roots of the polynomial $f(x) = 3x^3 - 4x - 5$ using the iterative Newton-Raphson method, the initial guess is taken to be $x = 2$. In the next iteration its value is nearest to
 (a) 1.671 (b) 1.656 (c) 1.559 (d) 1.551
- Q50. For a particle of energy E and momentum p (in a frame F), the rapidity y is defined as $y = \frac{1}{2} \ln\left(\frac{E + p_3c}{E - p_3c}\right)$. In a frame F' moving with velocity $v = (0, 0, \beta c)$ with respect to

F , the rapidity y' will be

- (a) $y' = y + \frac{1}{2} \ln(1 - \beta^2)$ (b) $y' = y - \frac{1}{2} \ln\left(\frac{1 + \beta}{1 - \beta}\right)$
 (c) $y' = y + \ln\left(\frac{1 + \beta}{1 - \beta}\right)$ (d) $y' = y + 2 \ln\left(\frac{1 + \beta}{1 - \beta}\right)$

Head office

fiziks, H.No. 40 D, G.F, Jia Sarai,
Near IIT, Hauz Khas, New Delhi-16
Phone: 011-26865455/+91-9871145498

Branch office

Anand Institute of Mathematics,
28-B/6, Jia Sarai, Near IIT
Hauz Khas, New Delhi-16

Q51. A canonical transformation $(q, p) \rightarrow (Q, P)$ is made through the generating function

$F(q, p) = q^2 p$ on the Hamiltonian

$$H(q, p) = \frac{p^2}{2\alpha q^2} + \frac{\beta}{4} q^4$$

where α and β are constants. The equations of motion for (Q, p) are

- (a) $\dot{Q} = \frac{P}{\alpha}$ and $\dot{P} = -\beta Q$ (b) $\dot{Q} = \frac{4P}{\alpha}$ and $\dot{P} = \frac{-\beta Q}{2}$
- (c) $\dot{Q} = \frac{P}{\alpha}$ and $\dot{P} = -\frac{2P^2}{Q} - \beta Q$ (d) $\dot{Q} = \frac{2P}{\alpha}$ and $\dot{P} = -\beta Q$

Q52. The Lagrangian of a system moving in three dimensions is

$$L = \frac{1}{2} m \dot{x}_1^2 + m (\dot{x}_2^2 + \dot{x}_3^2) - \frac{1}{2} k x_1^2 - \frac{1}{2} k (x_2 + x_3)^2$$

The independent constants of motion is/are

- (a) energy alone
- (b) only energy, one component of the linear momentum and one component of the angular momentum
- (c) only energy, one component of the linear momentum
- (d) only energy, one component of the angular momentum
- Q53. Consider a sphere S_1 of radius R which carries a uniform charge of density ρ . A smaller sphere S_2 of radius $a < \frac{R}{2}$ is cut out and removed from it. The centres of the two spheres are separated by the vector $\vec{b} = \frac{\hat{n}R}{2}$, as shown in the figure. The electric field at a point P inside S_2 is

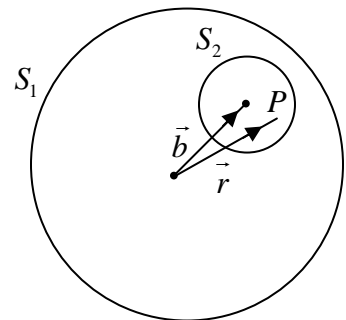

- (a) $\frac{\rho R}{3\epsilon_0} \hat{n}$ (b) $\frac{\rho R}{3\epsilon_0 a} (\vec{r} - \hat{n}a)$ (c) $\frac{\rho R}{6\epsilon_0} \hat{n}$ (d) $\frac{\rho a}{3\epsilon_0 R} \vec{r}$

Head office

fiziks, H.No. 40 D, G.F, Jia Sarai,
Near IIT, Hauz Khas, New Delhi-16
Phone: 011-26865455/+91-9871145498

Branch office

Anand Institute of Mathematics,
28-B/6, Jia Sarai, Near IIT
Hauz Khas, New Delhi-16

Q54. The value of the electric and magnetic fields in a particular reference frame (in Gaussian units) are $E = 3\hat{x} + 4\hat{y}$ and $B = 3\hat{z}$ respectively. An inertial observer moving with respect to this frame measures the magnitude of the electric field to be $|E'| = 4$. The magnitude of the magnetic field $|B'|$ measured by him is

- (a) 5 (b) 9 (c) 0 (d) 1

Q55. A loop of radius a , carrying a current I , is placed in a uniform magnetic field B . If the normal to the loop is denoted by \hat{n} , the force \vec{F} and the torque \vec{T} on the loop are

- (a) $\vec{F} = 0$ and $\vec{T} = \pi a^2 I \hat{n} \times B$ (b) $\vec{F} = \frac{\mu_0}{4\pi} \vec{I} \times \vec{B}$
 (c) $\vec{F} = \frac{\mu_0}{4\pi} \vec{I} \times \vec{B}$ and $\vec{T} = I \hat{n} \times \vec{B}$ (d) $\vec{F} = 0$ and $\vec{T} = \frac{1}{\mu_0 \epsilon_0} I \vec{B}$

Q56. A waveguide has a square cross-section of side $2a$. For the TM modes of wave vector k , the transverse electromagnetic modes are obtained in terms of a function $\psi(x, y)$ which obeys the equation

$$\left[\frac{\partial^2}{\partial x^2} + \frac{\partial^2}{\partial y^2} + \left(\frac{\omega^2}{c^2} - k^2 \right) \right] \psi(x, y) = 0$$

with the boundary condition $\psi(\pm a, y) = \psi(x, \pm a) = 0$. The frequency ω of the lowest mode is given by

- (a) $\omega^2 = c^2 \left(k^2 + \frac{4\pi^2}{a^2} \right)$ (b) $\omega^2 = c^2 \left(k^2 + \frac{\pi^2}{a^2} \right)$
 (c) $\omega^2 = c^2 \left(k^2 + \frac{\pi^2}{2a^2} \right)$ (d) $\omega^2 = c^2 \left(k^2 + \frac{\pi^2}{4a^2} \right)$

Head office

fiziks, H.No. 40 D, G.F, Jia Sarai,
 Near IIT, Hauz Khas, New Delhi-16
 Phone: 011-26865455/+91-9871145498

Branch office

Anand Institute of Mathematics,
 28-B/6, Jia Sarai, Near IIT
 Hauz Khas, New Delhi-16

Q57. Consider a particle of mass m in a potential $V(x) = \frac{1}{2}m\omega^2x^2 + g \cos kx$. The change in the ground state energy, compared to the simple harmonic potential $\frac{1}{2}m\omega^2x^2$, to first order in g is

- (a) $g \exp\left(-\frac{k^2\hbar}{2m\omega}\right)$ (b) $g \exp\left(\frac{k^2\hbar}{2m\omega}\right)$
 (c) $g \exp\left(-\frac{2k^2\hbar}{m\omega}\right)$ (d) $g \exp\left(-\frac{k^2\hbar}{4m\omega}\right)$

Q58. The energy levels for a particle of mass m in the potential $V(x) = \alpha|x|$, determined in the WKB approximation

$$\sqrt{2m} \int_a^b \sqrt{E - V(x)} dx = \left(n + \frac{1}{2}\right) \hbar \pi$$

(where a, b are the turning points and $n = 0, 1, 2, \dots$), are

- (a) $E_n = \left[\frac{\hbar \pi \alpha}{4\sqrt{m}} \left(n + \frac{1}{2}\right) \right]^{\frac{2}{3}}$ (b) $E_n = \left[\frac{3\hbar \pi \alpha}{4\sqrt{2m}} \left(n + \frac{1}{2}\right) \right]^{\frac{2}{3}}$
 (c) $E_n = \left[\frac{3\hbar \pi \alpha}{4\sqrt{m}} \left(n + \frac{1}{2}\right) \right]^{\frac{2}{3}}$ (d) $E_n = \left[\frac{\hbar \pi \alpha}{4\sqrt{2m}} \left(n + \frac{1}{2}\right) \right]^{\frac{2}{3}}$

Q59. A particle of mass m moves in one dimension under the influence of the potential $V(x) = -\alpha\delta(x)$, where α is a positive constant. The uncertainty in the product $(\Delta x)(\Delta p)$ in its ground state is

- (a) $2\hbar$ (b) $\frac{\hbar}{2}$ (c) $\frac{\hbar}{\sqrt{2}}$ (d) $\sqrt{2}\hbar$

Head office

fiziks, H.No. 40 D, G.F, Jia Sarai,
 Near IIT, Hauz Khas, New Delhi-16
 Phone: 011-26865455/+91-9871145498

Branch office

Anand Institute of Mathematics,
 28-B/6, Jia Sarai, Near IIT
 Hauz Khas, New Delhi-16

Q60. The ground state energy of a particle of mass m in the potential $V(x) = \frac{\hbar^2 \beta}{6m} x^4$,

estimated using the normalized trial wavefunction $\psi(x) = \left(\frac{\alpha}{\pi}\right)^{\frac{1}{4}} e^{-\frac{\alpha x^2}{2}}$, is

[use $\sqrt{\frac{\alpha}{\pi}} \int_{-\infty}^{\infty} dx x^2 e^{-\alpha x^2} = \frac{1}{2\alpha}$ and $\sqrt{\frac{\alpha}{\pi}} \int_{-\infty}^{\infty} dx x^4 e^{-\alpha x^2} = \frac{3}{4\alpha^2}$]

- (a) $\frac{3}{2m} \hbar^2 \beta^{\frac{1}{3}}$ (b) $\frac{8}{3m} \hbar^2 \beta^{\frac{1}{3}}$ (c) $\frac{2}{3m} \hbar^2 \beta^{\frac{1}{3}}$ (d) $\frac{3}{8m} \hbar^2 \beta^{\frac{1}{3}}$

Q61. Consider a gas of Cs atoms at a number density of 10^{12} atoms/cc. when the typical inter-particle distance is equal to the thermal de Broglie wavelength of the particles, the temperature of the gas is nearest to (Take the mass of a Cs atom to be 22.7×10^{-26} kg)

- (a) 1×10^{-9} K (b) 7×10^{-5} K (c) 1×10^{-3} K (d) 2×10^{-8} K

Q62. The internal energy $E(T)$ of a system at a fixed volume is found to depend on the temperature T as $E(T) = aT^2 + bT^4$. Then the entropy $S(T)$, as a function of temperature, is

- (a) $\frac{1}{2} aT^2 + \frac{1}{4} bT^4$ (b) $2aT^2 + 4bT^4$
 (c) $2aT + \frac{4}{3} bT^3$ (d) $2aT + 2bT^3$

Q63. A radioactive element X decays to Y , which in turn decays to a stable element Z . The decay constant from X to Y is λ_1 , and that from Y to Z is λ_2 . If, to begin with, there are only N_0 atoms of X , at short times ($t \ll \frac{1}{\lambda_1}$ as well as $\frac{1}{\lambda_2}$) the number of atoms of Z will be

- (a) $\frac{1}{2} \lambda_1 \lambda_2 N_0 t^2$ (b) $\frac{\lambda_1 \lambda_2}{2(\lambda_1 + \lambda_2)} N_0 t$
 (c) $(\lambda_1 + \lambda_2)^2 N_0 t^2$ (d) $(\lambda_1 + \lambda_2) N_0 t$

Head office

fiziks, H.No. 40 D, G.F, Jia Sarai,
 Near IIT, Hauz Khas, New Delhi-16
 Phone: 011-26865455/+91-9871145498

Branch office

Anand Institute of Mathematics,
 28-B/6, Jia Sarai, Near IIT
 Hauz Khas, New Delhi-16

Q64. Two completely overlapping semi-circular parallel plates comprise a capacitive transducer. One of the plates is rotated by an angle of 10° relative to their common centre. Ignoring edge effects, the ratio, $I_n : I_0$ of sensitivity of the transducer in the new configuration with respect to the original one, is

- (a) 8:9 (b) 11:12 (c) 17:18 (d) 35:36

Q65. The state diagram that detects three or more consecutive 1's in a serial bit stream is

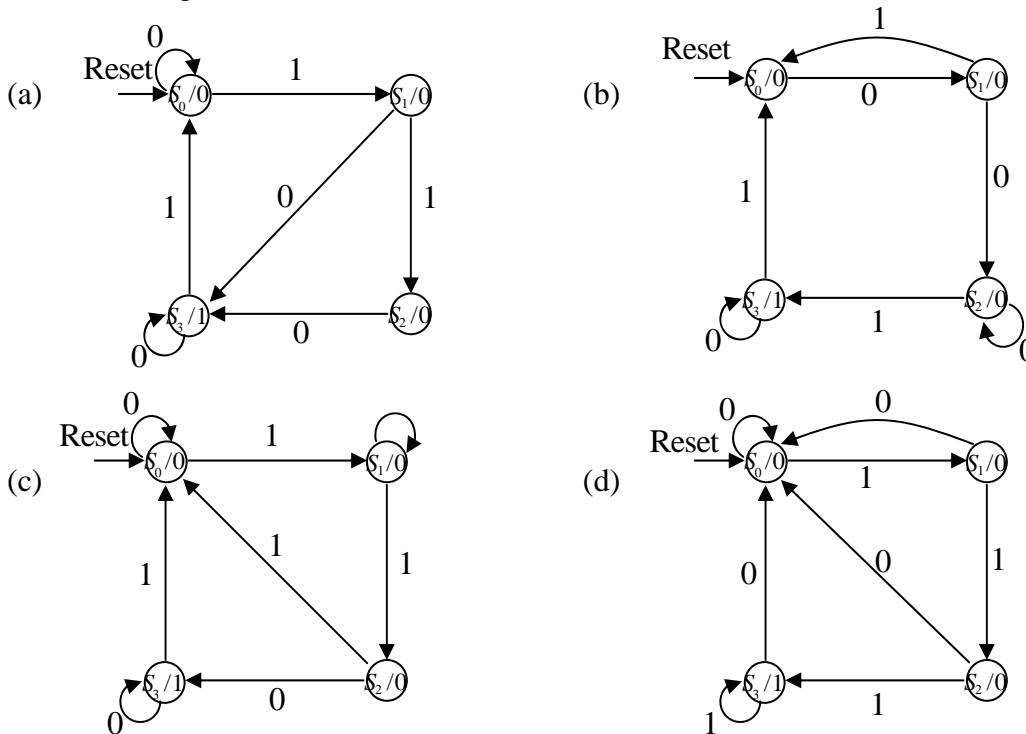

Q66. The decay constants f_p of the heavy pseudo-scalar mesons, in the heavy quark limit, are related to their masses m_p by the relation $f_p = \frac{a}{\sqrt{m_p}}$, where a is an empirical parameter to be determined. The values $m_p = 6400 \pm 160 \text{ MeV}$ and $f_p = 180 \pm 15 \text{ MeV}$ correspond to uncorrelated measurements of a meson. The error on the estimate of a is

- (a) $175 (\text{MeV})^{\frac{3}{2}}$ (b) $900 (\text{MeV})^{\frac{3}{2}}$ (c) $1200 (\text{MeV})^{\frac{3}{2}}$ (d) $2400 (\text{MeV})^{\frac{3}{2}}$

Head office

fiziks, H.No. 40 D, G.F, Jia Sarai,
Near IIT, Hauz Khas, New Delhi-16
Phone: 011-26865455/+91-9871145498

Branch office

Anand Institute of Mathematics,
28-B/6, Jia Sarai, Near IIT
Hauz Khas, New Delhi-16

Q67. Consider electrons in graphene, which is a planar monatomic layer of carbon atoms. If the dispersion relation of the electrons is taken to be $\varepsilon(k) = ck$ (where c is constant) over the entire k -space, then the Fermi energy ε_F depends on the number density of electrons ρ as

- (a) $\varepsilon_F \propto \rho^{\frac{1}{2}}$ (b) $\varepsilon_F \propto \rho$ (c) $\varepsilon_F \propto \rho^{\frac{2}{3}}$ (d) $\varepsilon_F \propto \rho^{\frac{1}{3}}$

Q68. Suppose the frequency of phonons in a one-dimensional chain of atoms is proportional to the wave vector. If n is the number density of atoms and c is the speed of the phonons, then the Debye frequency is

- (a) $2\pi cn$ (b) $\sqrt{2}\pi cn$ (c) $\sqrt{3}\pi cn$ (d) $\frac{\pi cn}{2}$

Q69. The band energy of an electron in a crystal for a particular k -direction has the form $\varepsilon(k) = A - B \cos 2ka$, where A and B are positive constants and $0 < ka < \pi$. The electron has a hole-like behaviour over the following range of k :

- (a) $\frac{\pi}{4} < ka < \frac{3\pi}{4}$ (b) $\frac{\pi}{2} < ka < \pi$
(c) $0 < ka < \frac{\pi}{4}$ (d) $\frac{\pi}{2} < ka < \frac{3\pi}{4}$

Q70. The ground state electronic configuration of ^{22}Ti is $[\text{Ar}]3d^24s^2$. Which state, in the standard spectroscopic notations, is not possible in this configuration?

- (a) 1F_3 (b) 1S_0 (c) 1D_2 (d) 3P_0

Q71. In a normal Zeeman Effect experiment using a magnetic field of strength $0.3 T$, the splitting between the components of a 660 nm spectral line is

- (a) 12 pm (b) 10 pm (c) 8 pm (d) 6 pm

Q72. The separation between the energy levels of a two-level atom is 2 eV . Suppose that 4×10^{20} atoms are in the ground state and 7×10^{20} atoms are pumped into the excited state just before lasing starts. How much energy will be released in a single laser pulse?

- (a) $24.6 J$ (b) $22.4 J$ (c) $98 J$ (d) $48 J$

Head office

fiziks, H.No. 40 D, G.F, Jia Sarai,
Near IIT, Hauz Khas, New Delhi-16
Phone: 011-26865455/+91-9871145498

Branch office

Anand Institute of Mathematics,
28-B/6, Jia Sarai, Near IIT
Hauz Khas, New Delhi-16

- Q73. In the large hadron collider (LHC), two equal energy proton beams traverse in opposite directions along a circular path of length 27 km . If the total centre of mass energy of a proton-proton pair is 14 TeV , which of the following is the best approximation for the proper time taken by a proton to traverse the entire path?
- (a) 12 ns (b) $1.2\ \mu\text{s}$ (c) 1.2 ns (d) $0.12\ \mu\text{s}$
- Q74. Let E_s denotes the contribution of the surface energy per nucleon in the liquid drop model. The ratio $E_s\left({}_{13}^{27}\text{Al}\right):E_s\left({}_{30}^{64}\text{Zn}\right)$ is
- (a) 2:3 (b) 4:3 (c) 5:3 (d) 3:2
- Q75. According to the shell model, the nuclear magnetic moment of the ${}_{27}^{13}\text{Al}$ nucleus is (Given that for a proton $g_l = 1$, $g_s = 5.586$, and for a neutron $g_l = 0$, $g_s = -3.826$)
- (a) $-1.913\ \mu_N$ (b) $14.414\ \mu_N$ (c) $4.793\ \mu_N$ (d) 0

Head office

fiziks, H.No. 40 D, G.F, Jia Sarai,
Near IIT, Hauz Khas, New Delhi-16
Phone: 011-26865455/+91-9871145498

Branch office

Anand Institute of Mathematics,
28-B/6, Jia Sarai, Near IIT
Hauz Khas, New Delhi-16